

Monitoring Magnetic Fields for Advanced LIGO

Christina Daniel

Mentor: Robert Schofield

LIGO Hanford Observatory

How can ambient magnetic fields affect Advanced LIGO?

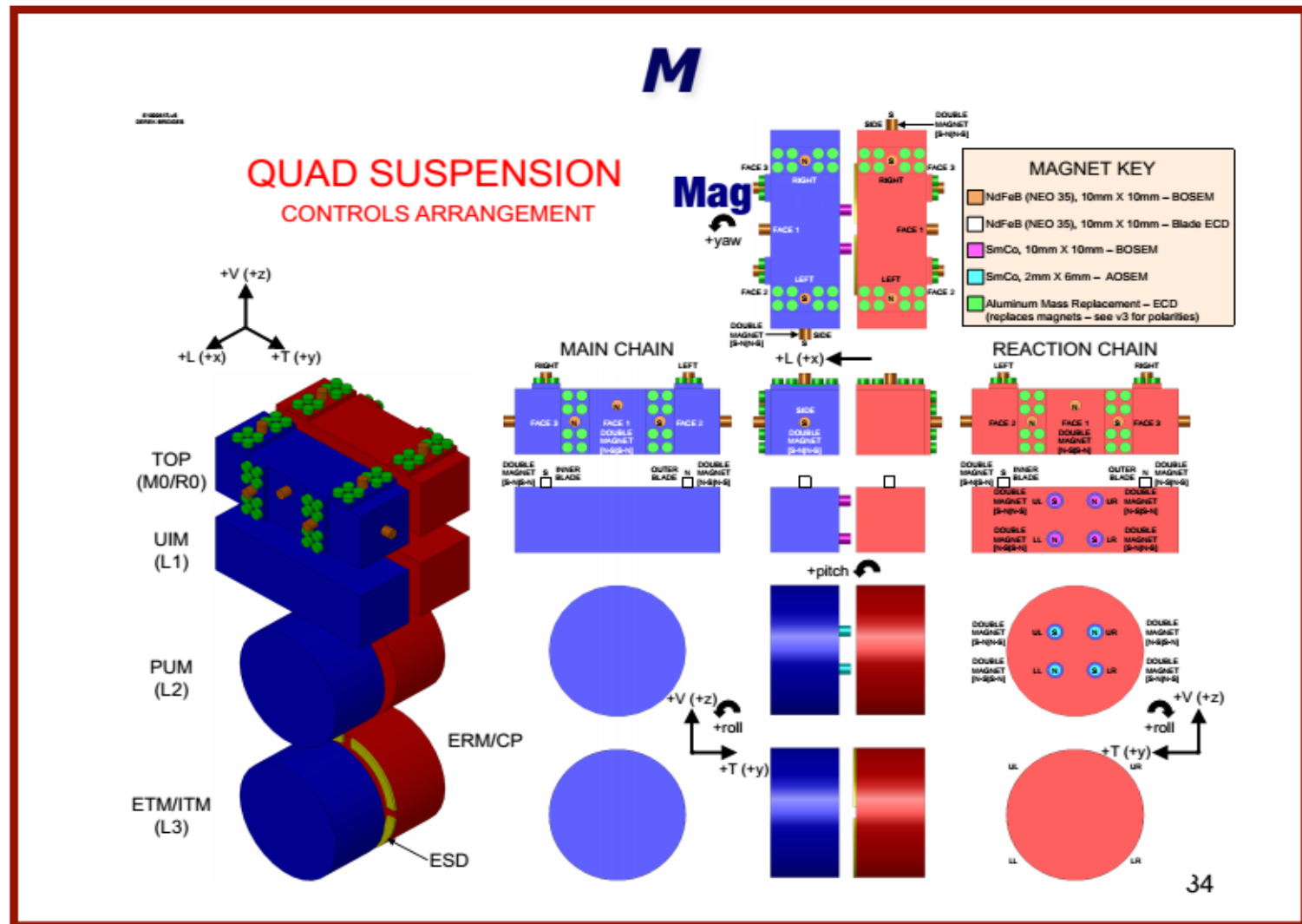

Magnetometer Data Acquisition System

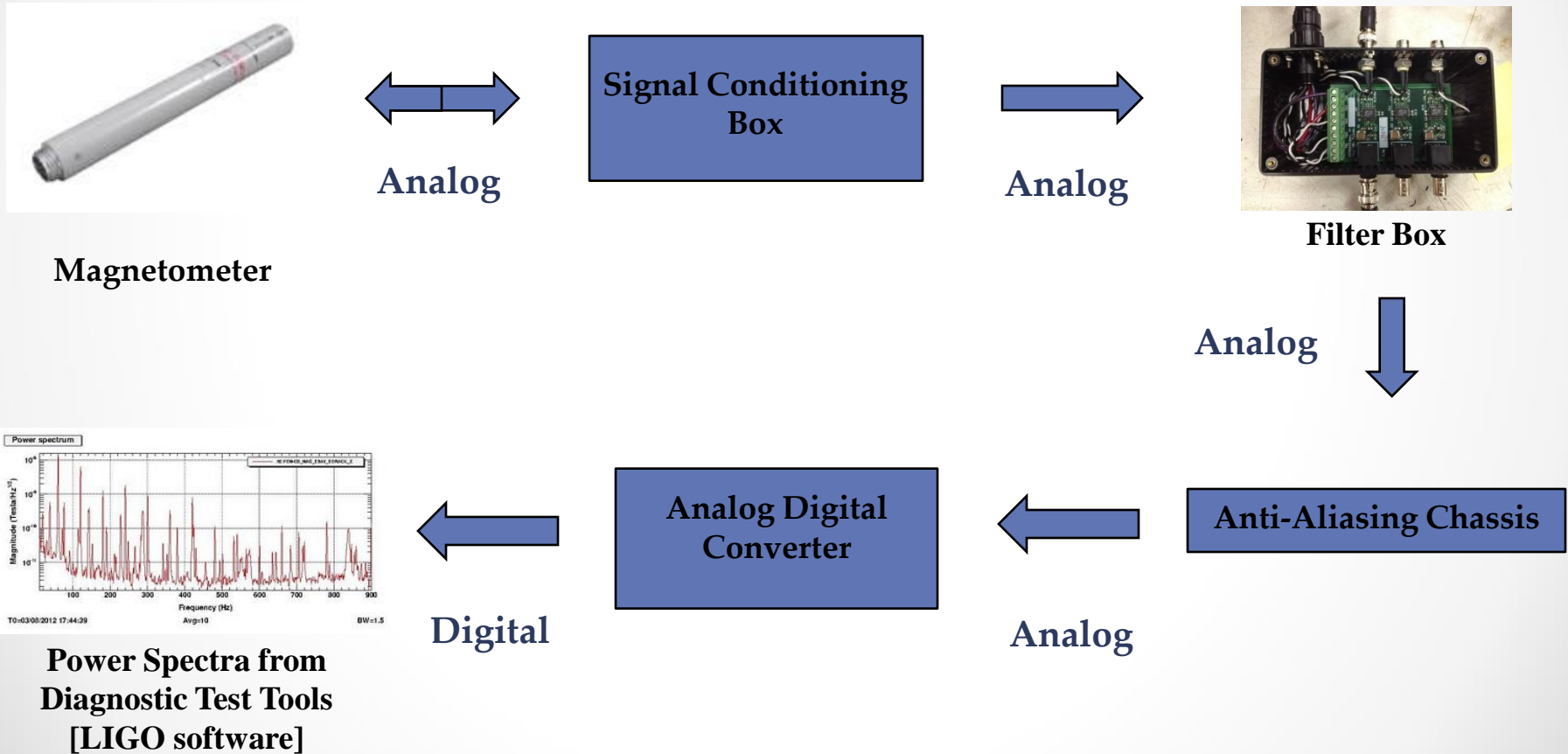

Filter Box Modification

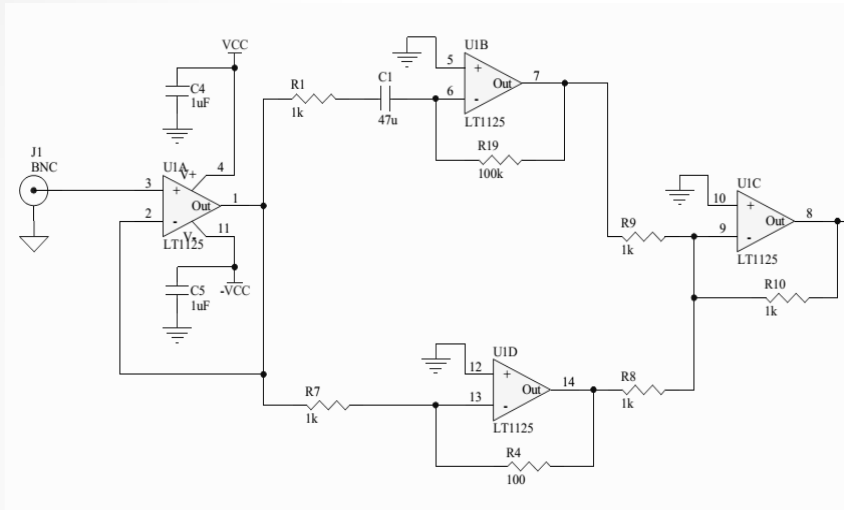

$$f = \frac{1}{wRC}$$

$$Gain = \frac{R_1}{R_2}$$

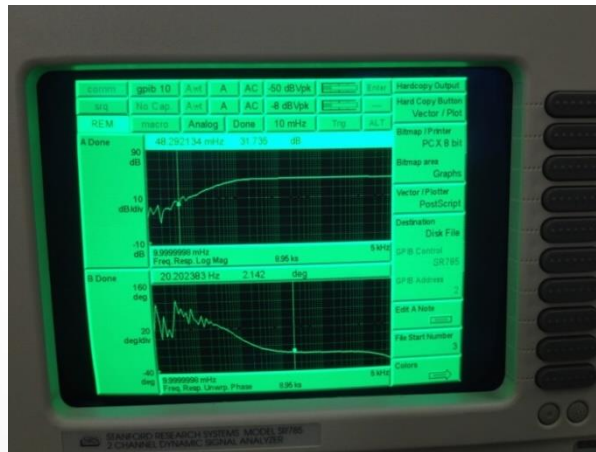

Magnetometer Installation – LVEA and End Y Electronics Bay

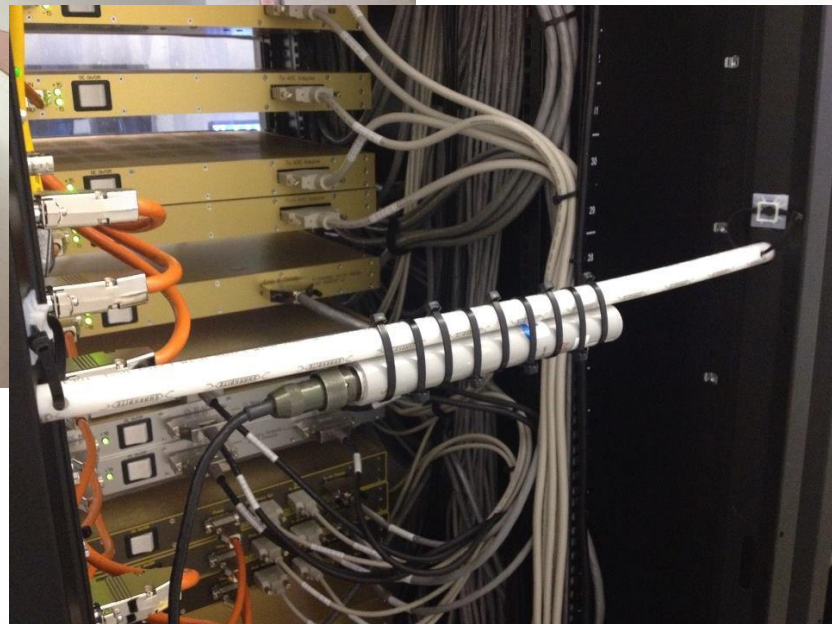
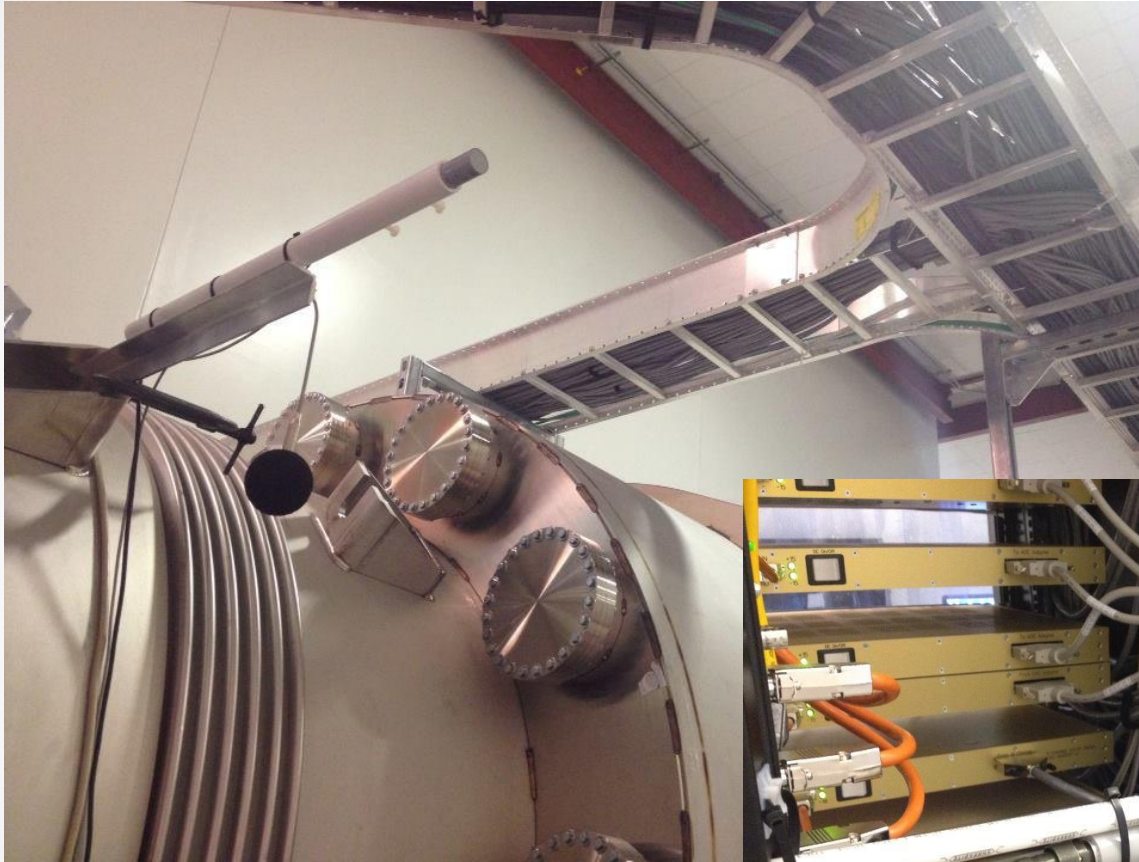

Magnetometer Calibration

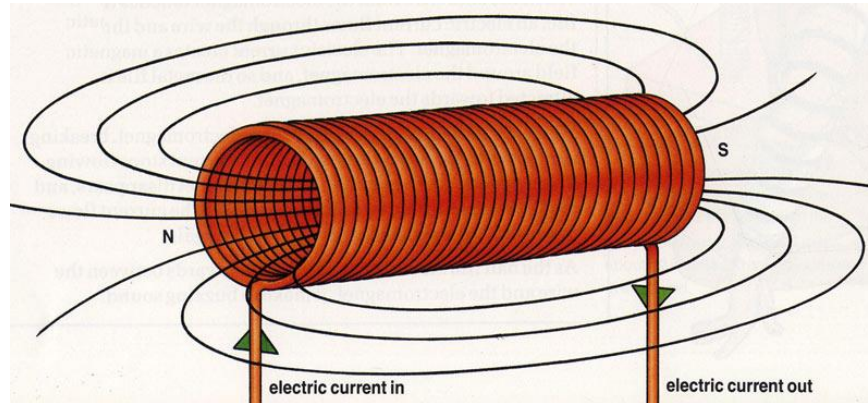

$$\oint \vec{B} \cdot d\vec{l} = \mu_0 I_{enc}$$

$$B = \mu_0 \frac{N}{l} I$$



What about other magnetic fields?

- So far, we have considered site-specific fields
- But certain “global” magnetic fields can act like gravitational waves passing through both sites
- Lower the Advanced LIGO noise floor by subtracting these fields from the gravitational wave channel for the stochastic gravitational wave search
 - Geomagnetic Field Observatory possibility



Source of Schumann Resonances: Lightening

- Lightening, an electrostatic discharge

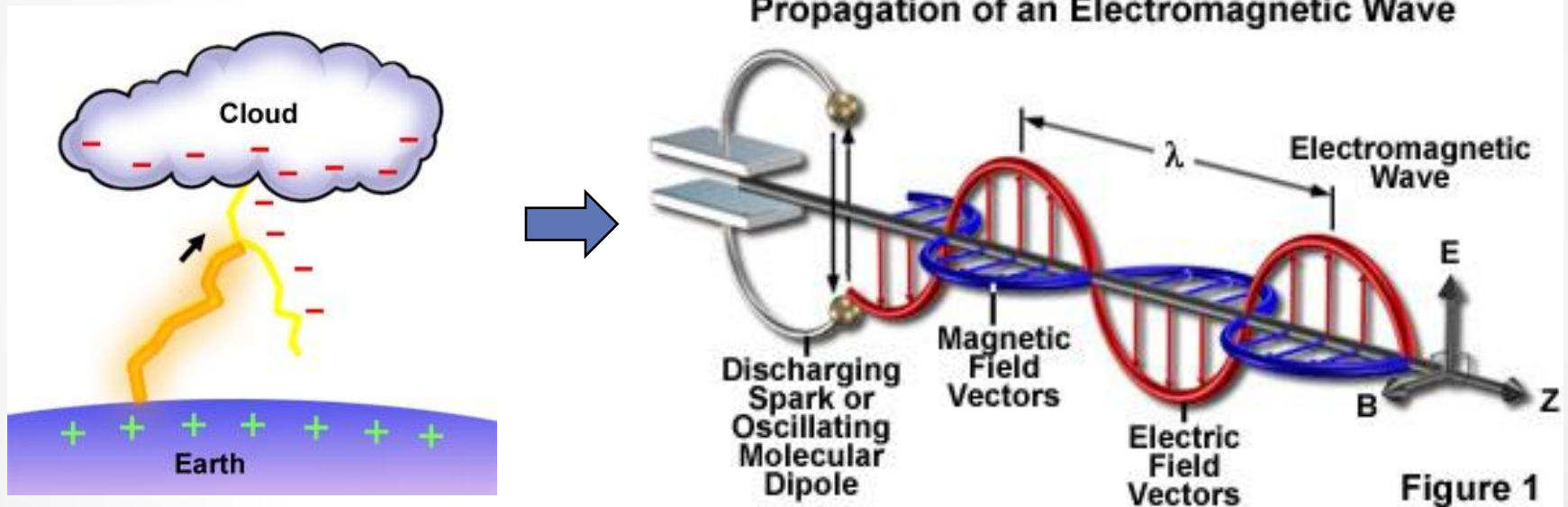

- Sudden discharge produces an electromagnetic wave

Schumann Resonances (Continued)

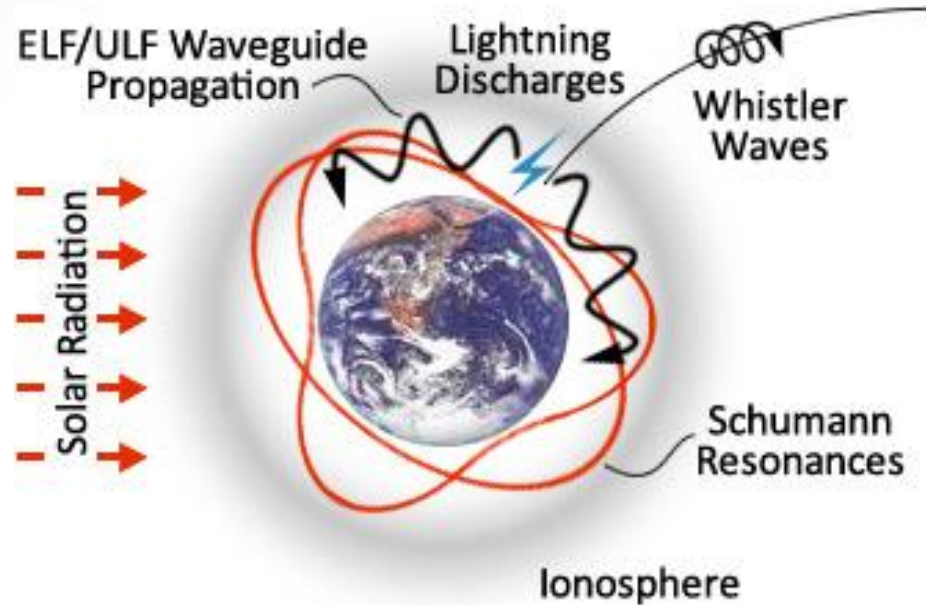

- An electromagnetic wave from a lightning strike propagates spherically, resonating between the ionosphere and the Earth's surface
- Resonant frequencies: 7.8 Hz (fundamental), 14.3 Hz, 20.8 Hz, ... , 60 Hz
- Light travels around the world in 1/8th of a second

Comparing the Sites

- 60 Hz peak gets smaller with magnetic isolation
- Schumann Resonances not covered up in Table Mountain plot

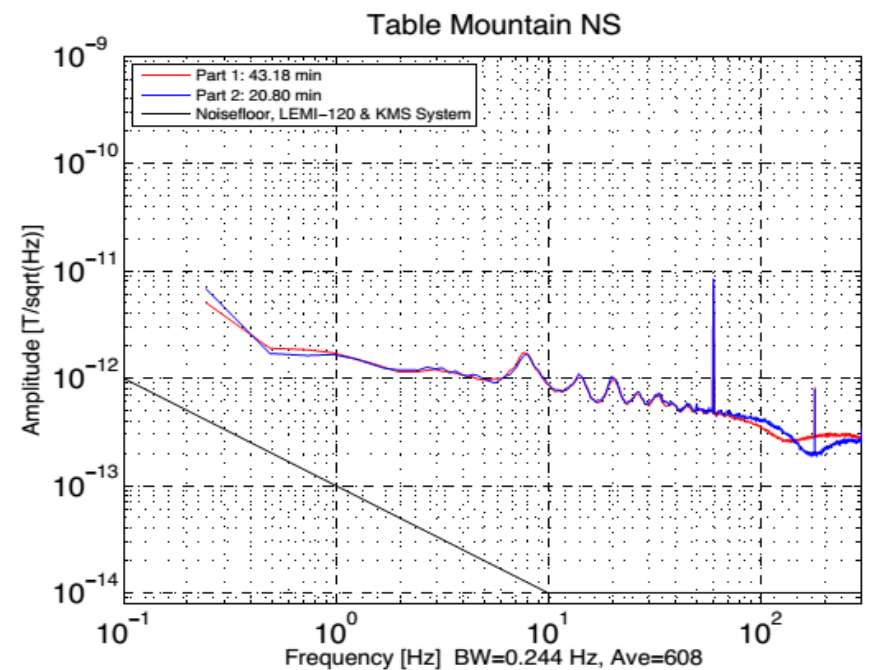
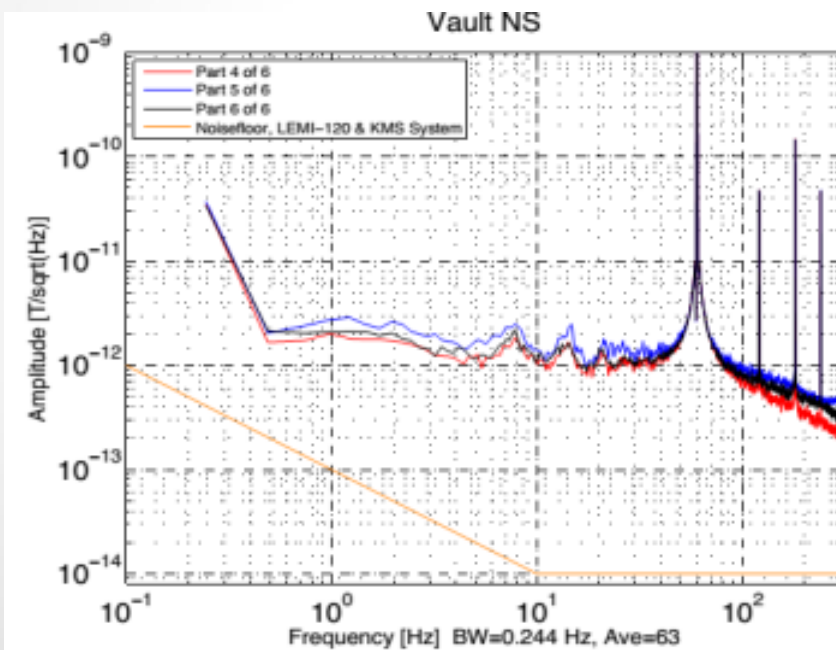

Viewing the Same Data in a Different Way

- Ultra Low Frequency (ULF) wave: 1mHz – 1Hz
- 0.01 Hz Resonance – pc4 frequency band within ULF range

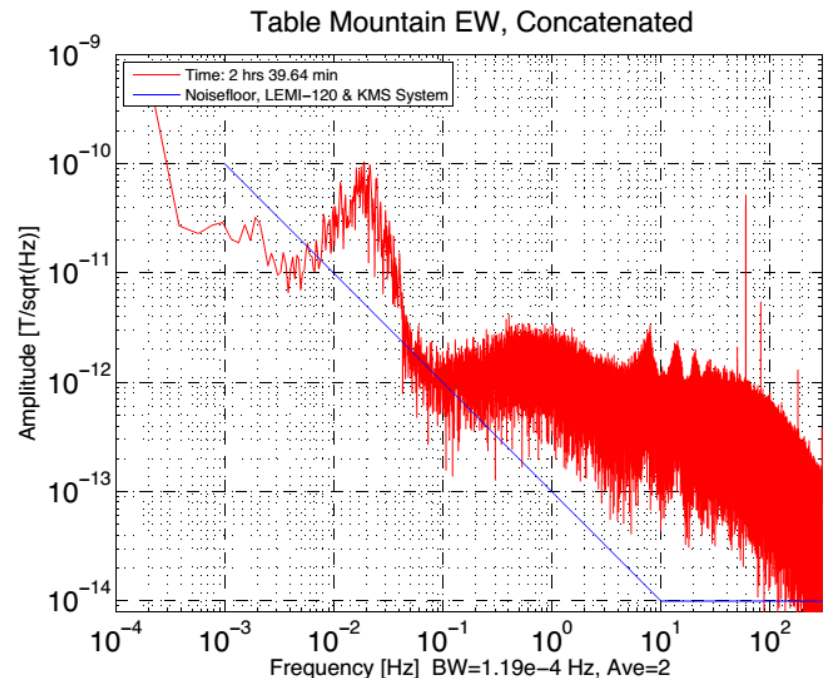
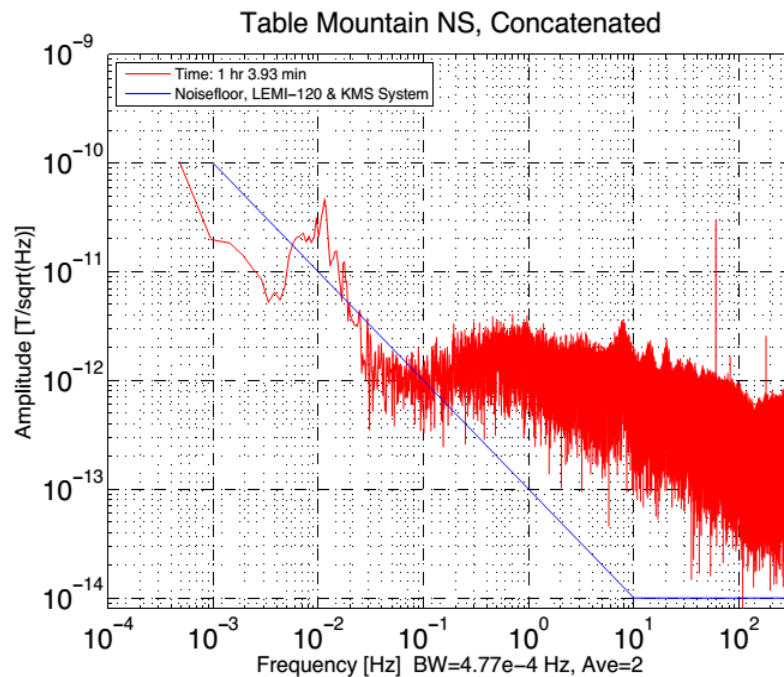

How close can electronic devices be to the interferometer?

- Uninterruptible Power Supply (UPS) for the Pre-Stabilized Laser (PSL)
- Lights simulate load from pre-stabilized laser
- Set-up variables
 1. Angle
 2. Distance
 3. On/off configurations



First power spectra

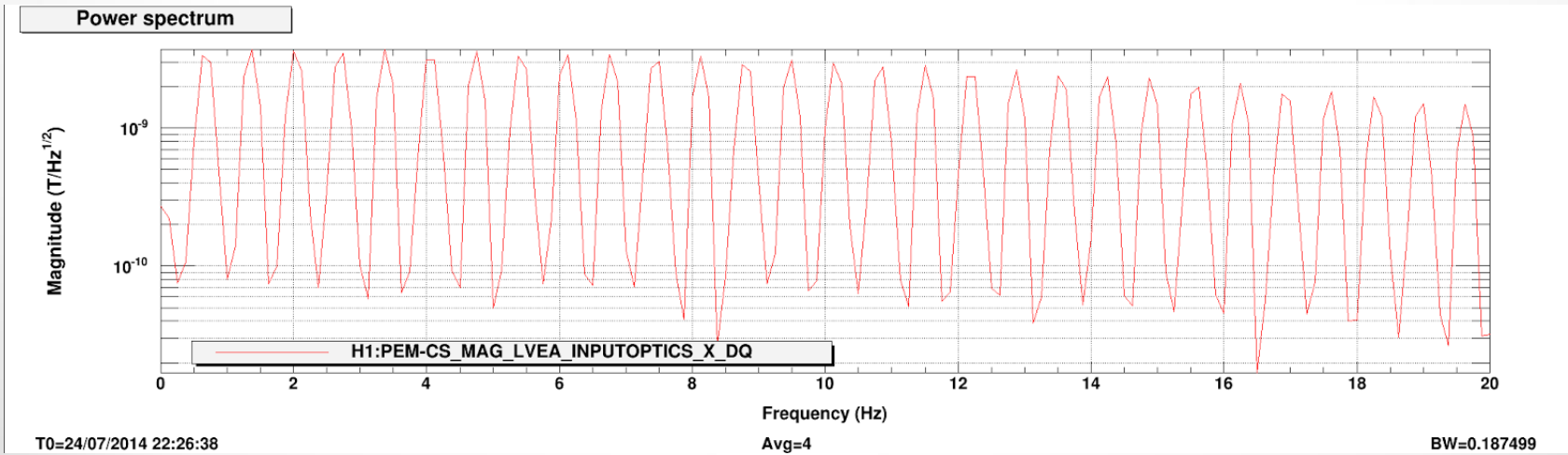
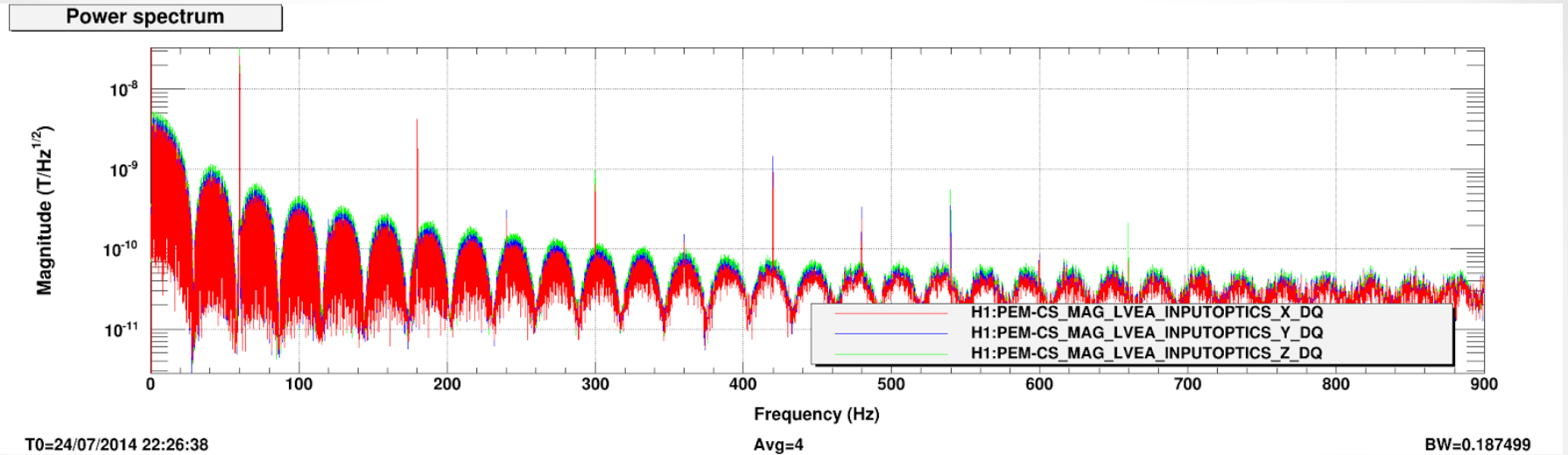

Fourier Analysis - 1

- Time (T) between glitches: 1.5 seconds

- $$f = \frac{1}{T} = \frac{1}{1.5} = .67 \text{ Hz}$$

H1:PEM-CS_MAG_LVEA_INPUTOPTICS_X_DQ t=5s at
4096Hz
2014-07-24 22:26:38 UTC (1090276014)

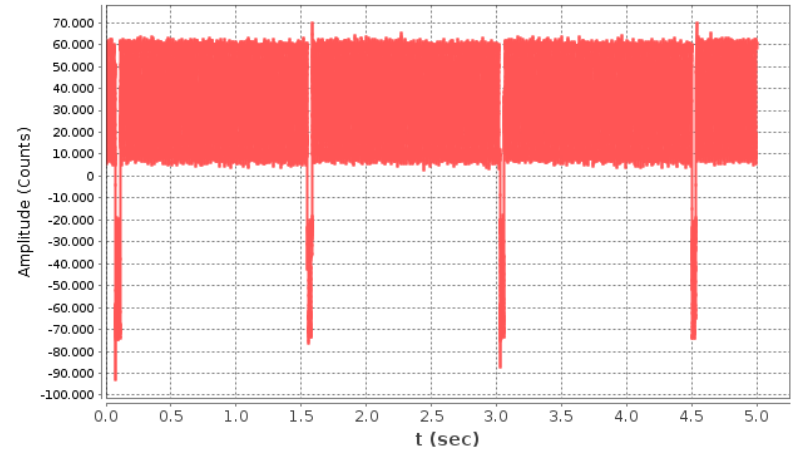

Power spectrum

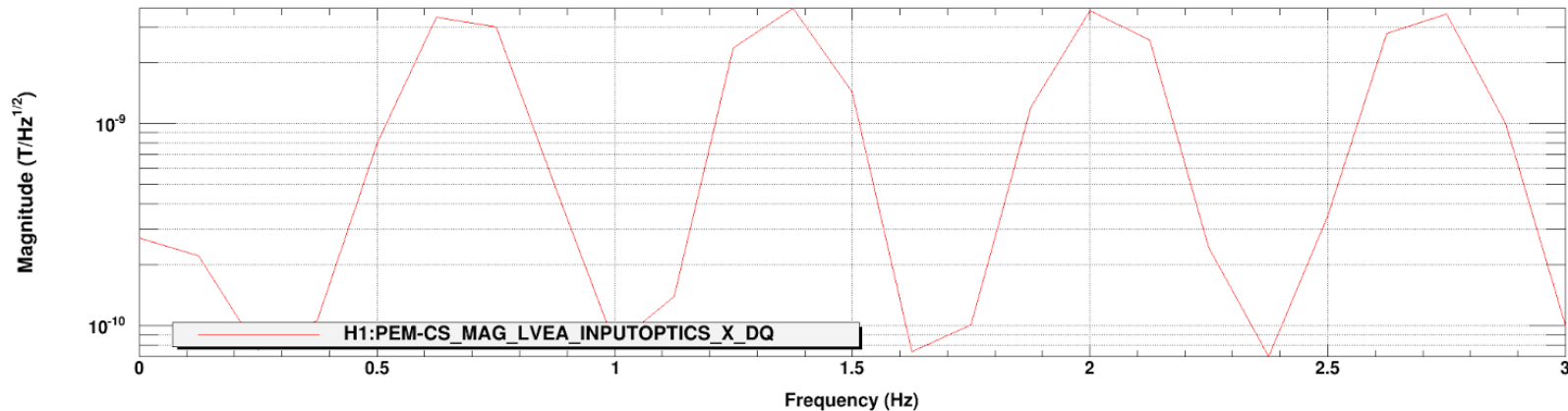

T0=24/07/2014 22:26:38

Avg=4

BW=0.187499

Fourier Analysis - 2

- Time (T) of glitch: .04 seconds

- $$f = \frac{1}{T} = \frac{1}{.04} = 25 \text{ Hz}$$

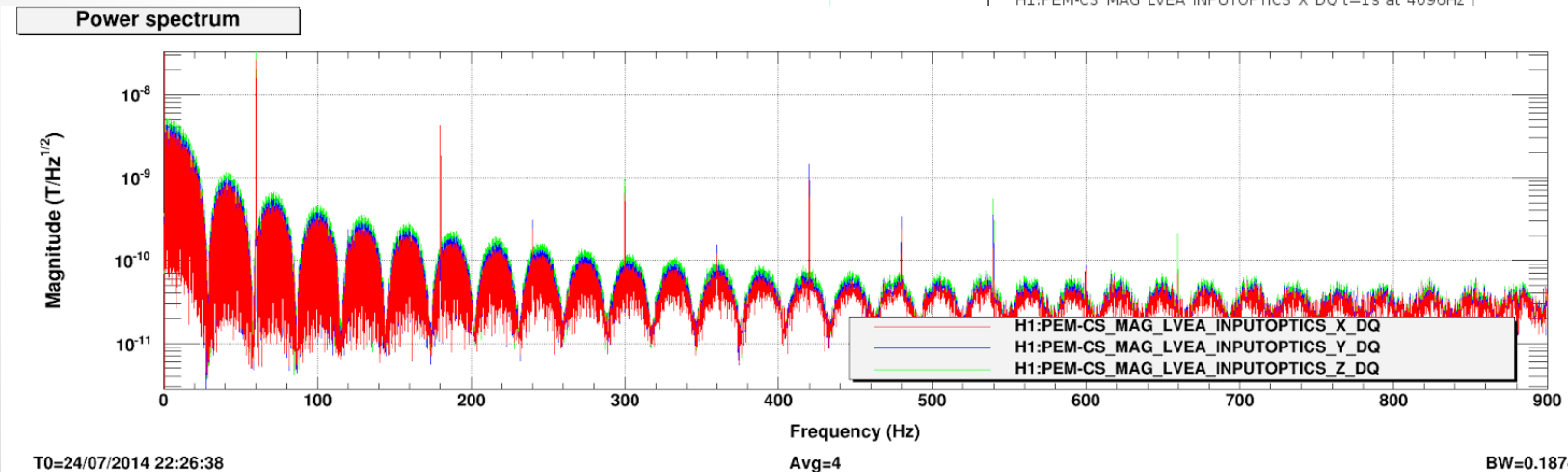
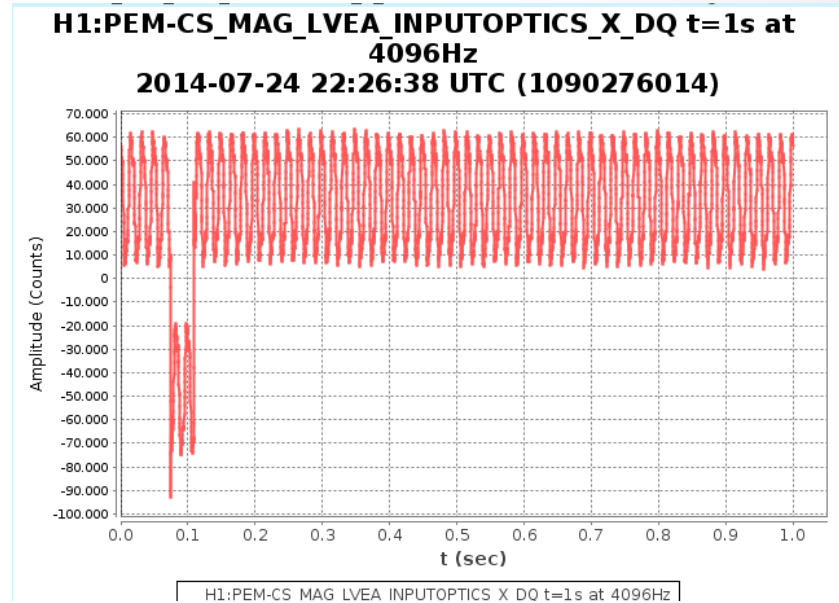

Magnetic field from UPS system

- 1m
- 90°
- Off & plugged vs. off & unplugged
- Our spec for 60 Hz peak is .5 nT – one tenth of the average field during old science runs

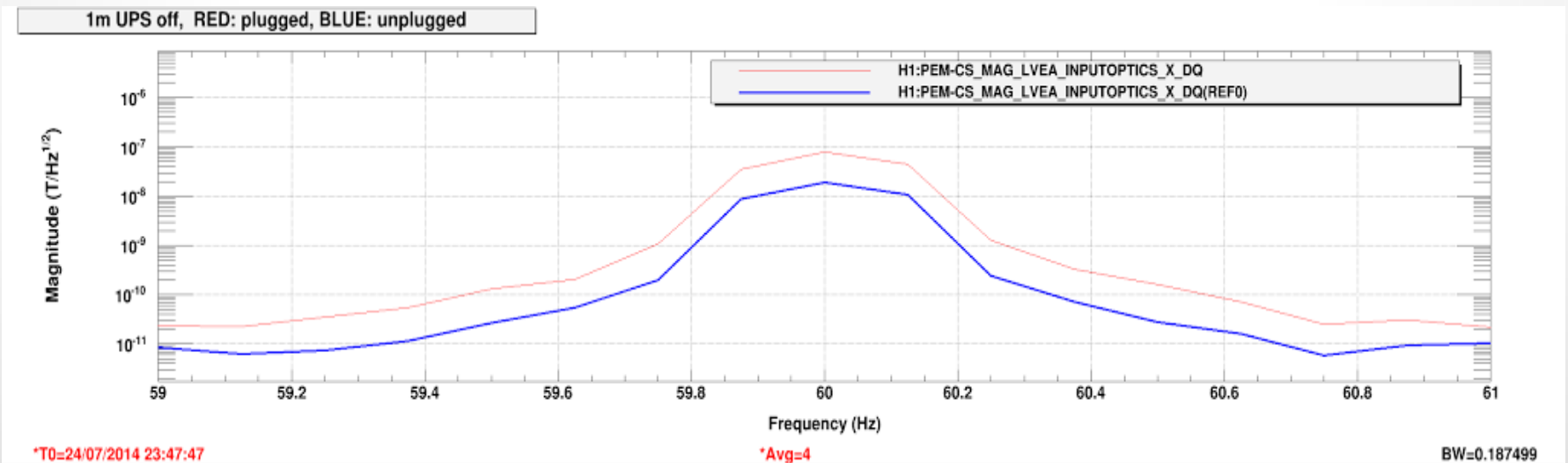

Future Work

1. Magnetometers
 1. Custom magnetometer mounts
 2. DC power to signal conditioning boxes
 3. Filter box modifications + check transfer functions
 4. Cabling
 5. Calibration
2. UPS system
 1. Improve measurement of attenuation of magnetic field with distance
3. Investigate magnetic coupling to:
 1. Seismometer
 2. Gravitational wave channel (if interferometer is active)

Thank you...

...for a rewarding and exciting summer at LIGO!

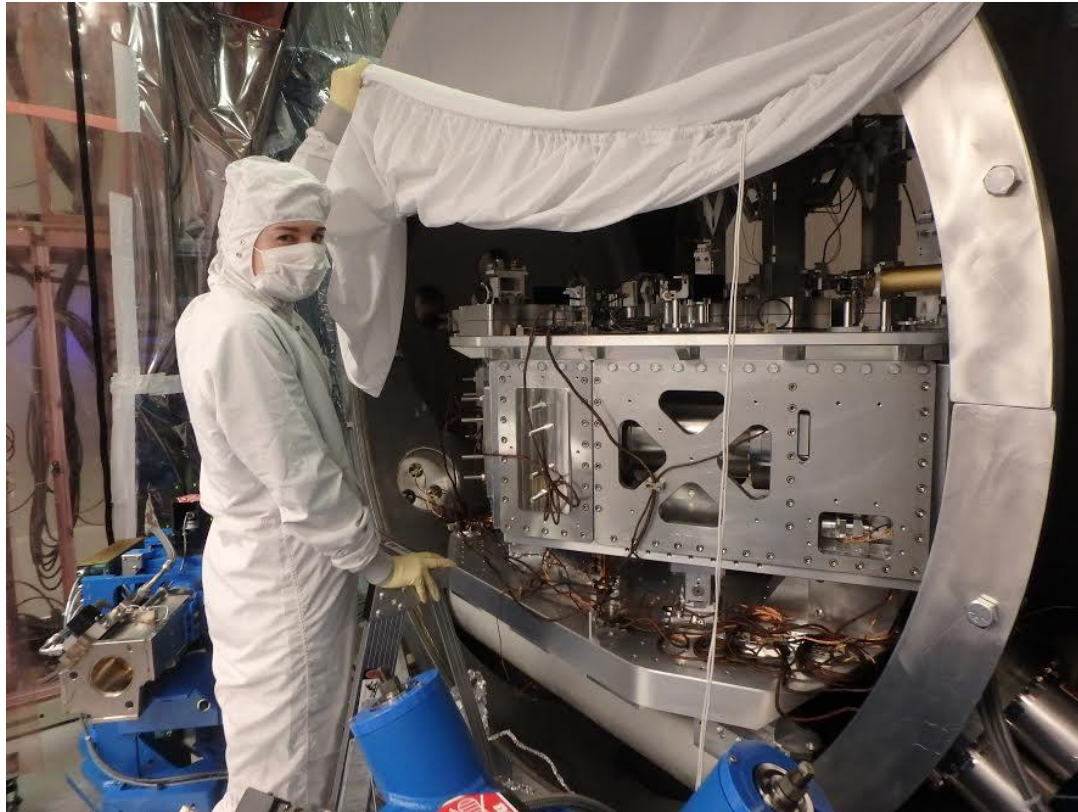

Acknowledgements

Robert Schofield, Richard McCarthy, Terra Hardwick
LIGO SURF Program